

*Designers & Manufacturers of Drilling & Tapping Solutions*

VISIBLE-GRIP adjustable tap holders are accurate, practical and lightweight. Tap changing is simple since one holder accurately adjusts to all tap sizes within its range.

There are two sets of jaws to guarantee true-running, powerful grip and positive drive. One set of adjustable precision-ground jaws center the tap by gripping on the shank diameter. Another set of adjustable jaws grip the tap square for positive rigid drive. There are NO loose parts such as collets and sleeves.

VISIBLE-GRIP tap holders are ideal for use on automatic or hand screw machines or drill presses with reversing motors. They are a proven product which has been used on Ettco high speed friction drive tappers for decades.

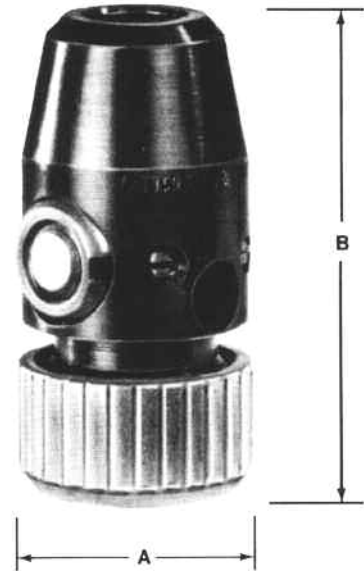

**Ordering Information:**

1. Order by part number as shown in tabulation.
2. Specify quantity.

REPLACEMENT PARTS					
Series	Body No.	Rebuilding Kit No. ‡	Chuck No.	Body No.	Rebuilding Kit No. ‡
1A	5561.068-01	5561.900-00	4D	5564.061-01	5564.900-00
1E	5561.060-01	5561.900-00	4E	5564.060-01	5564.900-00
2E	5562.060-01	5561.900-00	5D	5564.066-01	5565.900-00
3C	5563.061-01	5563.900-00	5E	5564.065-01	5565.900-00
3D	5563.062-01	5563.900-00	5J	5564.067-01	5565.900-00
3E	5563.060-01	5563.900-00			

‡Note: Rebuilding kit includes cap, shank jaws, jaw springs, R&L screw, R&L square jaws and retaining screws.

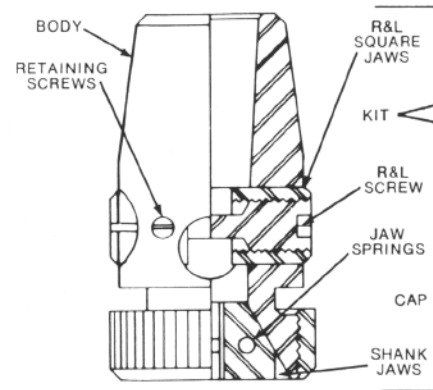

SPECIFICATIONS								
Series	Part Number	Capacity*		Used on Tapper	Body Hole Taper/Straight	Dimensions		
		Hand Tap	Pipe Tap			A†	B†	C
1A	5561.068-00	No. 0 to 1/2	1/16 & 1/8 SS	—	1 Jacobs	1.50	2.69	1.44
1E	5561.060-00	No. 0 to 1/2	1/16 & 1/8 SS	1B	20 Ettco	1.50	2.69	1.44
2E	5562.060-00	No. 0 to 1/2	1/16 & 1/8 SS	2B	2 Jacobs	1.50	2.69	1.44
3C	5563.061-00	No. 10 to 5/8	1/16 & 1/8	—	2 Jacobs	1.69	3.31	1.87
3D	5563.062-00	No. 10 to 3/4	1/16 & 1/8	—	3 Jacobs	1.69	3.31	1.87
3E	5563.060-00	No. 10 to 5/8	1/16 & 1/8	3B	6855 Dia.	1.69	3.31	1.87
4D	5564.061-00	1/4 to 3/4	1/16 to 1/4	—	3 Jacobs	1.75	3.31	1.94
4E	5564.060-00	1/4 to 3/4	1/16 to 1/4	4B	7 Jarno	1.75	3.31	1.94
5D	5564.066-00	3/16 to 1"	3/8 & 1/2	—	3 Jacobs	2.37	3.81	1.87
5E	5564.065-00	3/16 to 1"	3/8 & 1/2	5B	7 Jarno	2.37	3.81	1.87
5J	5564.067-00	3/16 to 1"	3/8 & 1/2	—	8 1/4 Jarno	2.37	3.81	1.87

\* Refer to A.S.A. standards for square, shank and overall length dimensions. Caution, pipe tap projection from chuck is small and clearances should be checked.  
 † Tap projection equals tap overall length + dim "C" — dim "B".  
 ‡ Dimensions shown are maximum and will decrease as tap size decreases.  
 SS = Small shank 1/4 pipe tap.



3445 Lonergan Drive, Rockford, IL 61125 • Tel: 815/874-9421 Fax: 815/874-9425 • www.rockford-ettco.com  
 304 Winston Creek Parkway, Lakeland, FL 33810 • Tel: 863/688-0071 Fax: 863/682-6233 • www.procunier.com

Rockford-Ettco reserves the right to modify product design in the interest of improving quality.

© 2007 Rockford-Ettco

Form REP071-8-5